

Universal High Brightness LED Driver with Temperature Compensation

General Description

The GA1910 is a peak current mode control LED driver IC. The GA1910 operates in constant off-time mode. It allows efficient operation of High Brightness (HB) LEDs with voltage sources ranging from 8VDC to 450VDC or 110VAC/220VAC. The GA1910 includes a PWM dimming input that can accept an external control signal with a duty ratio of 0 - 100% and a frequency of up to a few kilohertz. It also includes a 50 - 240mV linear dimming input which can be used both for linear dimming and temperature compensation of the LED current.

The GA1910 is ideally suited for buck LED drivers. Since the GA1910 operates in peak current mode control, the controller achieves good output current regulation without the need for any loop compensation. It achieves good PWM dimming response because the response time is limited only by the rate of rise and fall of the inductor current, enabling very fast rise and fall time.

Features

- Wide input range from 8VDC to 450VDC or 110VAC/220 VAC
- Temperature compensation to regulate LED current
- Application from a few mA to more than 1A output
- Constant off-time operation
- Linear and PWM dimming capability
- Requires few external components for operation

Applications

- DC/DC or AC/DC LED driver applications
- General purpose constant current source
- Signal and decorative LED lighting
- backlighting LED driver

Application Circuit

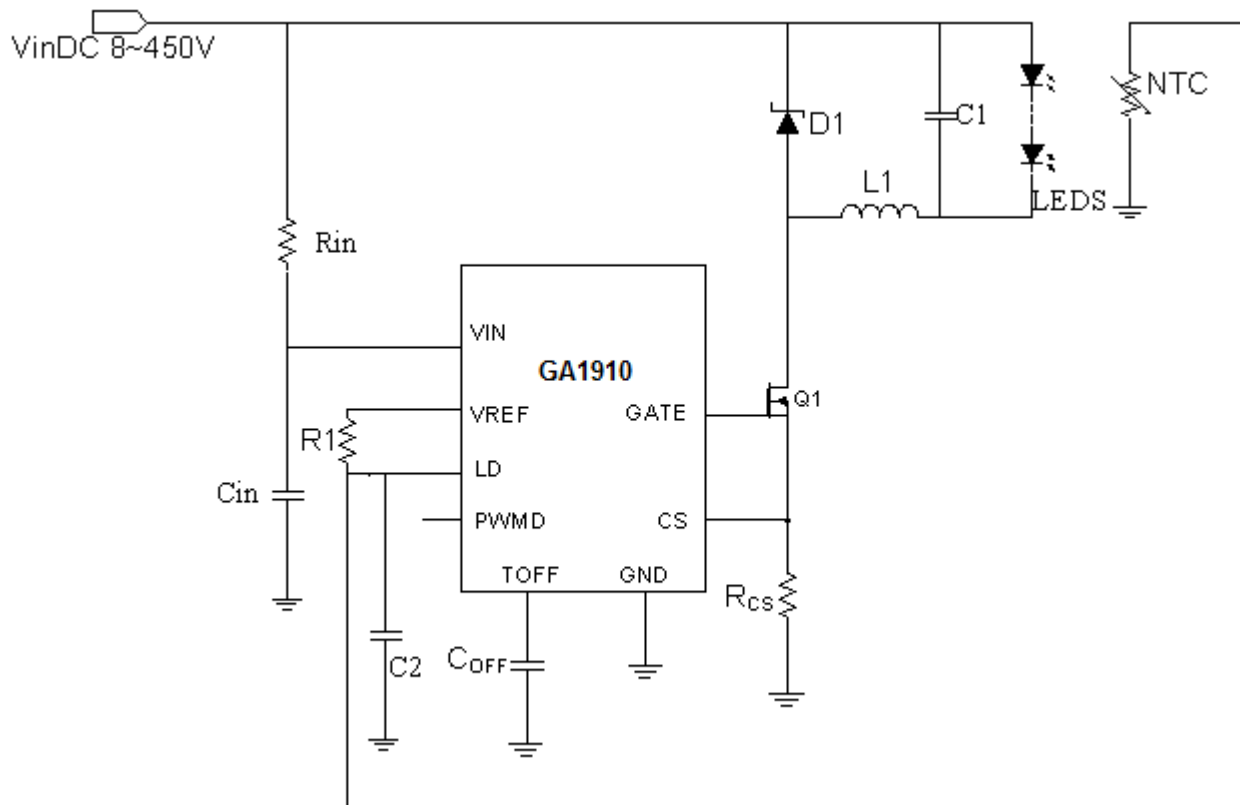

Pin Configurations

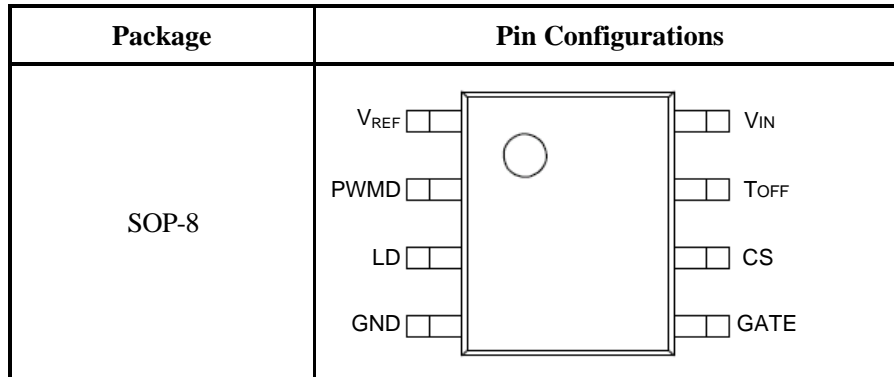

Pin Description

Pin	Pin No.	Description
V_{REF}	1	This pin provides a reference voltage of 1.2V, no bypass capacitor is needed.
PWMD	2	This is the PWM dimming input of the IC. When this pin is pulled to GND, the gate driver is turned off. When the pin is pulled high, the gate driver operates normally. Pull up to 3.3V internally via 100K resistor while floating
LD	3	This pin is the linear dimming input and sets the current sense threshold as long as the voltage at the pin is less than 240mV (typ). It can also used as temperature compensation threshold voltage.
GND	4	Ground return for all internal circuitry. This pin must be electrically connected to ground.
GATE	5	This pin is the output gate driver for an external N-channel power MOSFET.
CS	6	This pin is the current sense pin used to sense the MOSFET current by means of an external sense resistor. When this pin exceeds the lower of either the internal 240mV or the voltage at the LD pin, the gate output goes low.
T_{OFF}	7	This pin sets the off time of the power MOSFET. If left floating then the off time will be 510ns. When a capacitor is connected between T_{OFF} and GND, the off time is increased.
V_{IN}	8	This pin is the input of an 8V to 450V voltage supply through a resistor, clamped at 7.1V internally; it must be bypassed to GND with a capacitor as close as possible.

Ordering Information

Order Number	Quantity per reel	Package	Operating Temperature range
GA1910ID08E	2,500	SOP-8	-40 °C to 85 °C

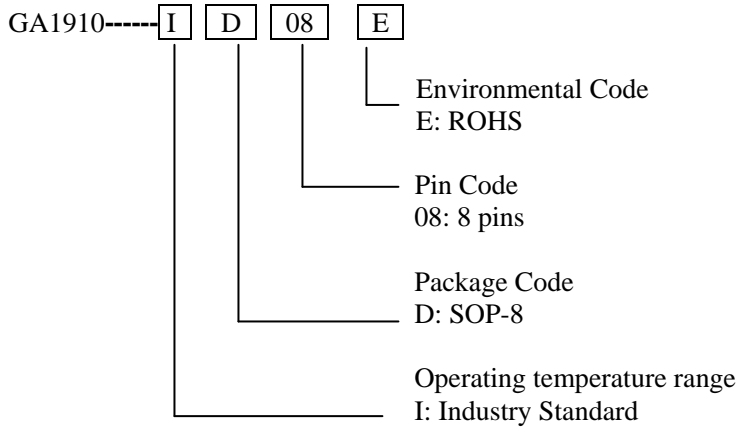

Absolute Maximum Ratings

Parameter	Value
V _{IN} pin voltage to GND	-0.3V to 8V
CS, LD, PWMD, GATE, T _{OFF} , V _{REF} pin voltage to GND	-0.3V to 6V
V _{IN} pin Input Current Range (Note1)	1mA to 10mA
Junction Temperature Range	-40 °C to 150 °C
Storage Temperature Range	-65 °C to 150 °C
ESD Human Model	2000V
R _{θJA}	80 °C/W

Electrical Characteristics (The specifications are at T_A=25 °C and V_{INDC}=10V (Note2), R_{IN}=2K, unless otherwise noted)

Symbol	Parameter	Conditions	Min.	Typ.	Max.	Unit
V _{INDC}	Input DC supply voltage range	Connect an appropriate resistor from DC supply voltage to V _{IN} pin (Note3)	8		450	V
V _{IN_clamp}	V _{IN} clamp voltage		6.6	7.1	7.6	V
I _{IN}	Operation current range	GATE floating	0.33	0.5	0.64	mA
UVLO	Undervoltage lockout threshold	V _{IN} rising	6.1	6.5	6.8	V
Δ UVLO	Undervoltage lockout hysteresis	V _{IN} falling		500		mV
V _{EN(lo)}	Pin PWMD input low voltage				1.2	V

$V_{EN(hi)}$	Pin PWM input high voltage		2			V
R_{EN}	Pin PWM pull-up resistance		90	100	110	K Ω
$V_{CS,TH}$	Current sense pull-in threshold voltage		215	240	265	mV
V_{LD}	Linear Dimming pin voltage low threshold			0.05		mV
	Linear Dimming pin voltage high threshold			0.24		mV
T_{BLANK}	Current sense blanking interval		400	478	550	ns
t_{DELAY}	Delay to output	$V_{CS}=V_{CS,TH}+50mV$ after T_{BLANK}		30		ns
T_{OFF}	Off Time	T_{OFF} pin Floating	480	510	550	ns
t_{RISE}	GATE output rise time	$C_{GATE}=500pF$		19		ns
t_{FALL}	GATE output fall time	$C_{GATE}=500pF$		29		ns
V_{REF}	REF pin voltage		1.12	1.20	1.30	V
$V_{REFLOAD}$	Load regulation of reference voltage	$I_{REF}=0\sim 500\mu A, PWM=5.0V$		0.5	5	mV

Note1: beyond the input current range, V_{IN} may not clamp at 7.1V.

Note2: V_{INDC} is the power supply to LED, and there should be an appropriate resistor between V_{INDC} and V_{IN} . All parameters are tested at 25 °C. Specifications over temperature are guaranteed by design

Note3: This parameter limit is guaranteed by design, characterization and application check.

Application Information

The GA1910 is optimized to drive buck LED drivers using peak current mode control. This control method provides fairly accurate LED current control without the need for a high side current sensing or the design of any additional loop compensation. The IC uses very few external components and provides for either Linear or PWM control of the LED current.

A capacitor connected to the T_{off} pin programs the off-time of the oscillator inside. The oscillator produces pulses at regular intervals. These pulses set the SR flip-flop in the GA1910 which causes the GATE driver to turn on. When the MOSFET turns on, the current through the inductor starts ramping up. This current flows through the external sense resistor R_{CS} and produces a ramp voltage at the CS pin. The comparators are constantly comparing the CS pin voltage to both the voltage at the LD pin and the internal 240mV. Once the blanking time is complete, the output of these comparators is allowed to reset the flip flop. When the output of either one of the two comparators goes high, the flip flop is reset and the GATE output goes low. If neither of the comparator goes high, the GATE goes low until the SR flip flop is set by the oscillator.

Assuming a 30% ripple in the inductor, the current sense resistor R_{CS} can be set using:

$$R_{CS} = \frac{0.24V(orV_{LD})}{1.15 \bullet I_{LED}(A)}$$

A constant off-time peak current control scheme can easily operate at duty cycles greater than 0.5 and also gives inherent input voltage rejection making the LED current almost insensitive to input voltage variations.

Input Voltage Regulator

When a voltage is applied through a suitable input resistor to the V_{IN} pin, the GA1910 maintains a constant 7.1V (typ.) at the V_{IN} pin. This voltage is used to power the IC. The V_{IN} pin must be bypassed by a low ESR capacitor to provide a low impedance path for the high frequency current of the output GATE driver.

The input current drawn from the V_{IN} pin is a sum of the 0.5mA(typ) current drawn by the internal circuit and the current drawn by the GATE driver (which in turn depends on the switching frequency and the GATE charge of the external MOSFET).

$$I_{IN} \approx 0.5mA + Q_G \bullet f_s$$

In the above equation, f_s is the switching frequency and Q_G is the GATE charge of the external MOSFET (which can be

obtained from the datasheet of the MOSFET).

Current Sense

The current sense input of the GA1910 goes to the noninverting inputs of two comparators. The inverting terminal of one comparator is tied to an internal 240mV reference whereas the inverting terminal of the other comparator is connected to the LD pin. The outputs of both these comparators are fed into an OR GATE and the output of the OR GATE is fed into the reset pin of the flip-flop. Thus, the comparator which has the lowest voltage at the inverting terminal determines when the GATE output is turned off.

The outputs of the comparators also include a typical 478ns blanking time which prevents spurious turn-offs of the external MOSFET due to the turn-on spike normally present in peak current mode control. In rare cases, this internal blanking time might not be enough to filter out the turn-on spike. In these cases, an external RC filter needs to be added between the external sense resistor (R_{CS}) and the CS pin.

Please note that the comparators are relatively fast with a typical 80ns response time. A proper layout minimizing external inductances will prevent false triggering of these comparators.

Oscillator

The oscillator in the GA1910 is controlled by a single capacitor connected at the T_{off} pin. The equation governing the T_{off} -time of oscillation period is given by:

$$T_{OFF_TIME}(s) = 0.51 \times 10^{-6} \times \left(1 + \frac{C_{OFF}}{10pF}\right)$$

Linear Dimming

The Linear Dimming pin is used to control the LED current. An external voltage ranging from 50mV to 240mV can be applied to the LD pin to adjust the LED current during operation. There are two cases when it may be necessary to use the Linear Dimming pin.

- ▶ In some cases, it may not be possible to find the exact R_{CS} value required to obtain the LED current when the internal 240mV is used. In these cases, an external voltage divider from the V_{in} pin can be connected to the LD pin to obtain a voltage (less than 240mV) corresponding to the desired voltage across R_{CS} .

- ▶ Linear dimming may be desired to adjust the current

level to reduce the brightness of the LEDs. Connecting a resistor between the Vref pin and the LD pin, and also connecting an NTC thermistor between the LD pin and ground (refer to **Application Circuit**), the GA1910 is able to realize the temperature compensation function (See more detail in **Temperature Compensation** section).

To use the internal 240mV, the LD pin must be connected to PWM pin.

PWM Dimming

PWM Dimming can be achieved by driving the PWM pin with a low frequency square wave signal. When the PWM signal is low, the GATE driver is disabled; and when the PWM signal is high, the GATE driver is enabled. Since the PWM signal does not turn off the other parts of the IC, the response of the GA1910 to the PWM signal is almost instantaneous. The rate of rise and fall of the LED current is thus determined solely by the rise and fall times of the inductor current.

To disable PWM dimming function, leave the PWM pin floating.

Temperature Compensation

GA1910 provides thermal protection for your LEDs. Refer to application figure, applying a NTC themistor close to the LEDs string will realize the temperature compensation of LEDs current. If the temperature of the LEDs rises, the resistance of the NTC thermistor decreases until the voltage of the LD pin falls below 0.24V. Then the average current is controlled by the LD pin and the temperature compensation function starts. The formula is as below:

$$\frac{R_{NTC} \cdot V_{ref}}{R_1 + R_{NTC}} = 0.24$$

Assuming a 30% ripple in the inductor, the temperature compensated continuous current may be computed as:

$$I_{out} = \frac{R_{NTC} \cdot V_{ref}}{(R_1 + R_{NTC}) \cdot R_s * 1.15}$$

Make sure the value of R1 is more than 1K.

When the LD pin voltage reduces to less than 50mv, the chip is shutdown .

After the ambient temperature returns to a safe temperature, the current will return to the set value.

Example

DC input voltage: $V_{INDC}=230V$

Output LED strings: $V_O=134.4V$ (42 LEDs in series, 3.2V

for each one),

$I_{O_AVG}=160mA$ (8 parallels LEDs, 20mA for each one)

IC input resistor (R_{IN}) and Hold Capacitor (C_{IN})

$I_{IN} \approx 0.5mA + Q_G \cdot f_s$, assume $I_{IN}=1mA$

$$R_{IN} = \frac{V_{INDC} - V_{IN}}{I_{IN}} = \frac{230 - 7.0}{1} \approx 223K$$

parallel two 430 k Ω /0.5W resistor for lifetime consideration. C_{IN} is chosen to be 10uF/ 40V capacitor

T_{off} Time regulation capacitor (Coff) and Toff Time

For higher output voltage, lower output current application, we need shorter T_{off} Time to obtain the application inductor smaller. For high output current application, it is suggested that the frequency is set no more than 50KHz(typical 25~30KHz) .In GA1910,

$$T_{OFF_TIME} = 0.51 \times 10^{-6} \times (1 + \frac{C_{OFF}}{10pF})$$

So, apply Coff =150pF, then $T_{off}=8.16us$

Current Sense Resistor (R_{cs})

Designing for low current ripple will improve current accuracy, but it also requires a large value of inductor. High current ripple allows a lower cost inductor. So we need to consider these two factors when selecting an inductor. A capacitor placed in parallel with the array of LEDs can be used to reduce the LED current ripple while keeping the same average current. A typical value is 1uf

Since the output average $I_{O_AVG} = 160mA$, then

$$I_{Ripple} = 0.5 \cdot 50\% \cdot 160mA = 40mA$$

$$I_{O_PEAK} = 200mA$$

$$R_{CS} = \frac{0.24V}{200mA} = 1.2\Omega$$

The Inductor (L_1) chosen

The inductor value depends on the ripple current in the LEDs. $T_{off}=8.16us$

$$L = \frac{V_O \times T_{OFF}}{I_{Ripple}} = \frac{134.4 \times 8.16}{80} \approx 13.7mH$$

The inductor chosen should have a saturation current higher than the peak output current and a continuous current rating above the required mean output current.

The DC resistance (DCR) of the inductor is also essential when choosing an inductor. Bigger DCR will lead to more heat. The value of the inductor will reduce as its temperature rises, leading to higher current ripple, which, in turn, reduces the average output current.

MOSFET (Q1) and Diode (D1)

The peak voltage seen by the MOSFET is equal to the maximum input voltage. Using a 50% safety rating,

$$V_{FET} = 1.5 \times V_{INDC}$$

The maximum RMS current through the MOSFET depends on the maximum current. Hence, the current rating of the MOSFET is:

$$I_{FET} = I_{PEAK} \bullet 150\%$$

For this application, choose a MOSFET 600V, 1A to 2A. 2N60 is good choice.

The peak voltage rating of the diode is the same as the FET. The current range of the diode is:

$$I_{diode} = I_{PEAK} \bullet 150\%$$

For this example, 600V/1A fast recovery diode is recommended.

Note: For different application, suggestions about components selection can be got from Good-Ark technical support.

Package Information:

SOP-8

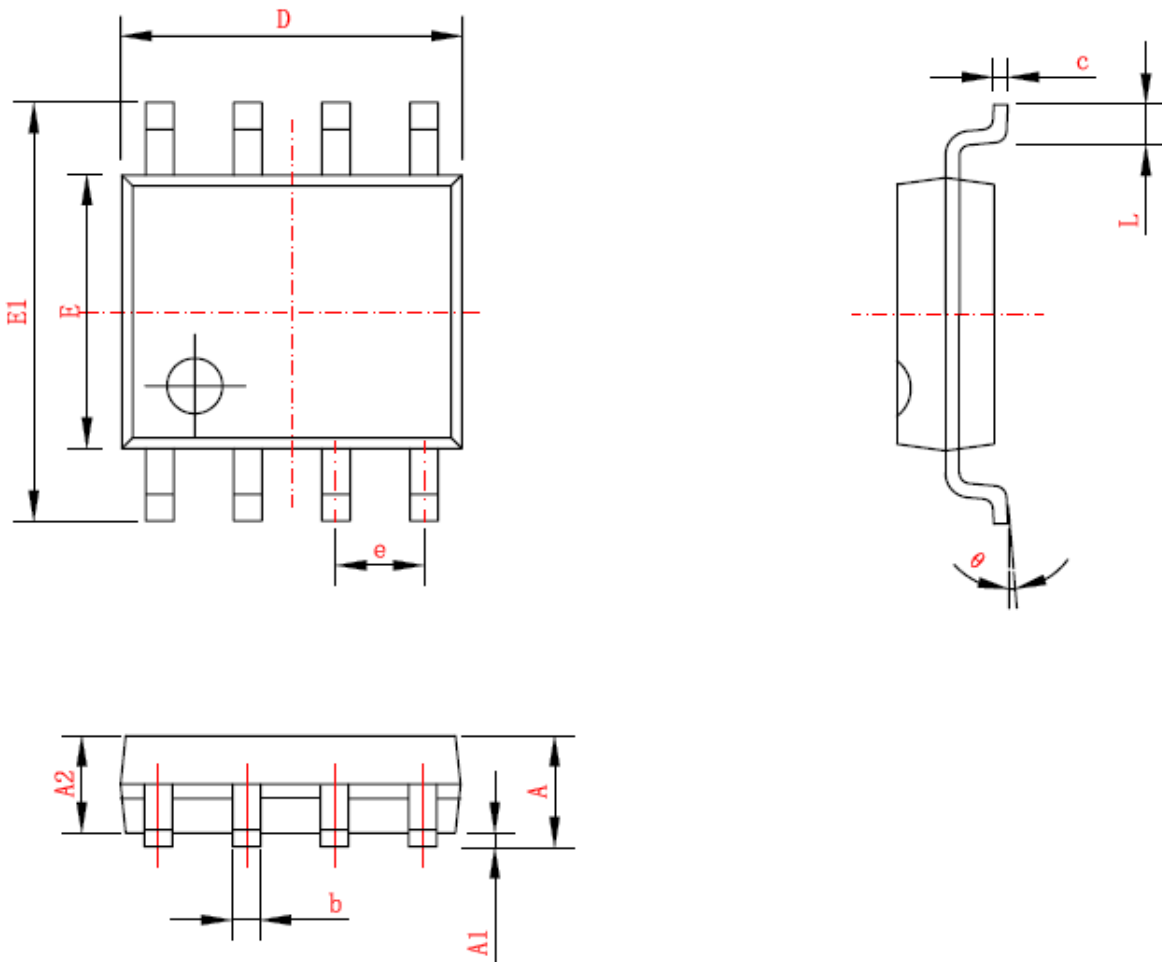



GOOD-ARK

GA1910

Symbol	Dimensions In Millimeters		Dimensions In Inches	
	Min	Max	Min	Max
A	1.350	1.750	0.053	0.069
A1	0.100	0.250	0.004	0.010
A2	1.450TYP		0.057TYP	
b	0.350	0.490	0.014	0.019
c	0.178	0.250	0.007	0.010
D	4.800	5.000	0.189	0.197
E	3.800	4.000	0.150	0.157
E1	5.800	6.240	0.228	0.246
e	1.270TYP		0.050TYP	
L	0.400	1.270	0.016	0.050
θ	0°	8°		